

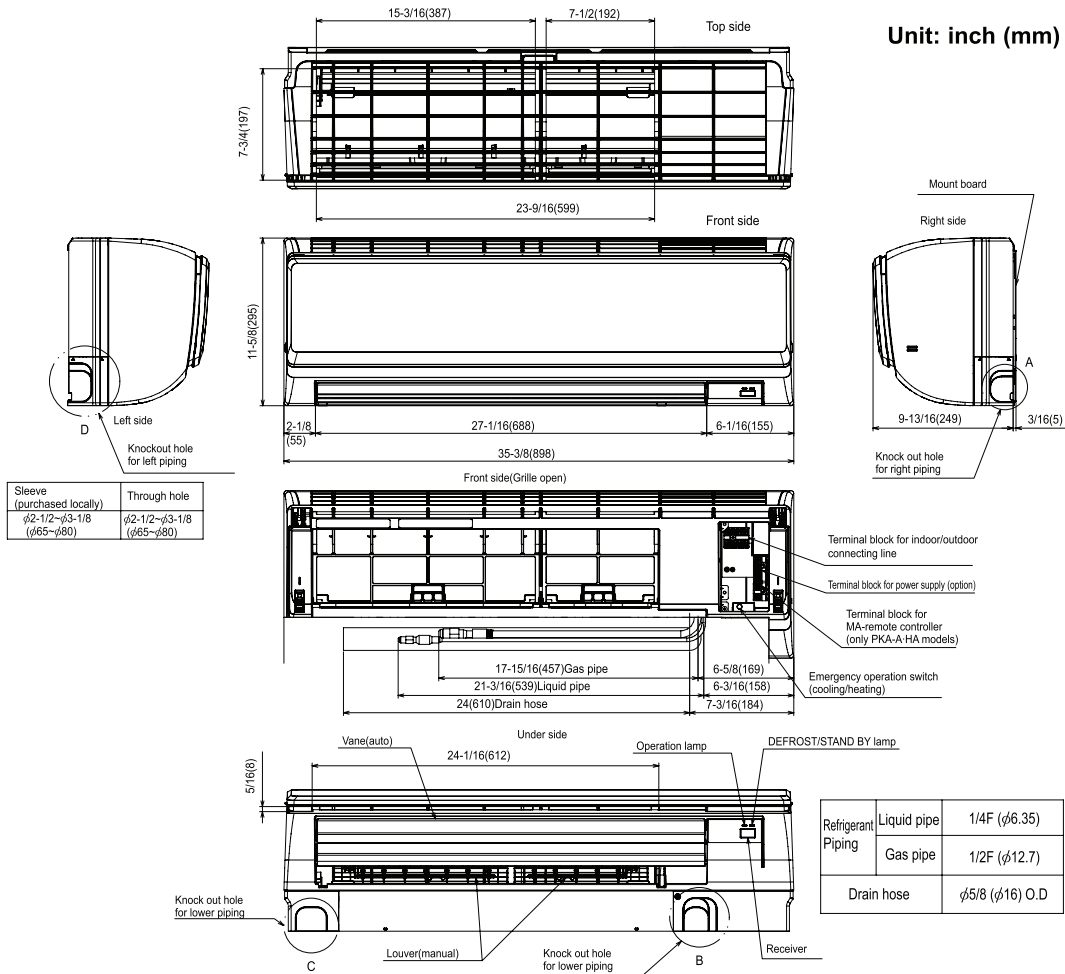

# DIMENSIONS: PKA-A18HA

Unit: inch (mm)



Refrigerant Piping	Liquid pipe	1/4" (φ6.35)
	Gas pipe	1/2" (φ12.7)
Drain hose		φ5/8 (φ16) O.D

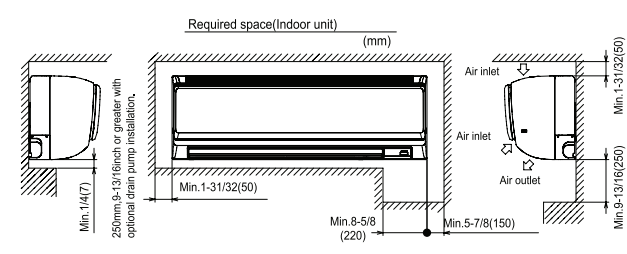
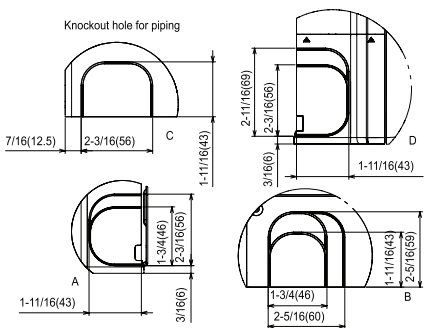
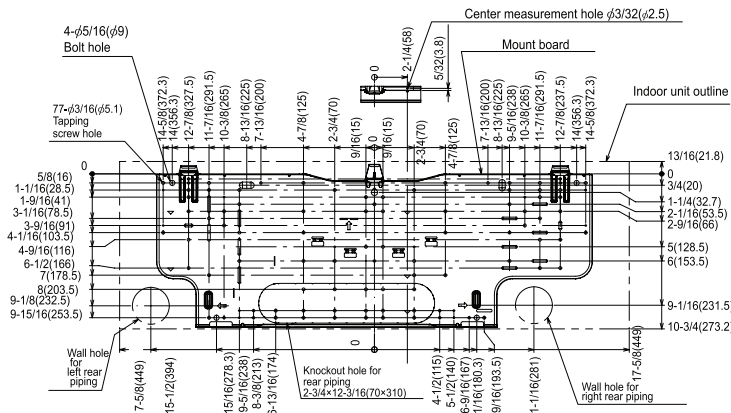

# DIMENSIONS: PUY-A18NHA3

Unit: mm (inch)

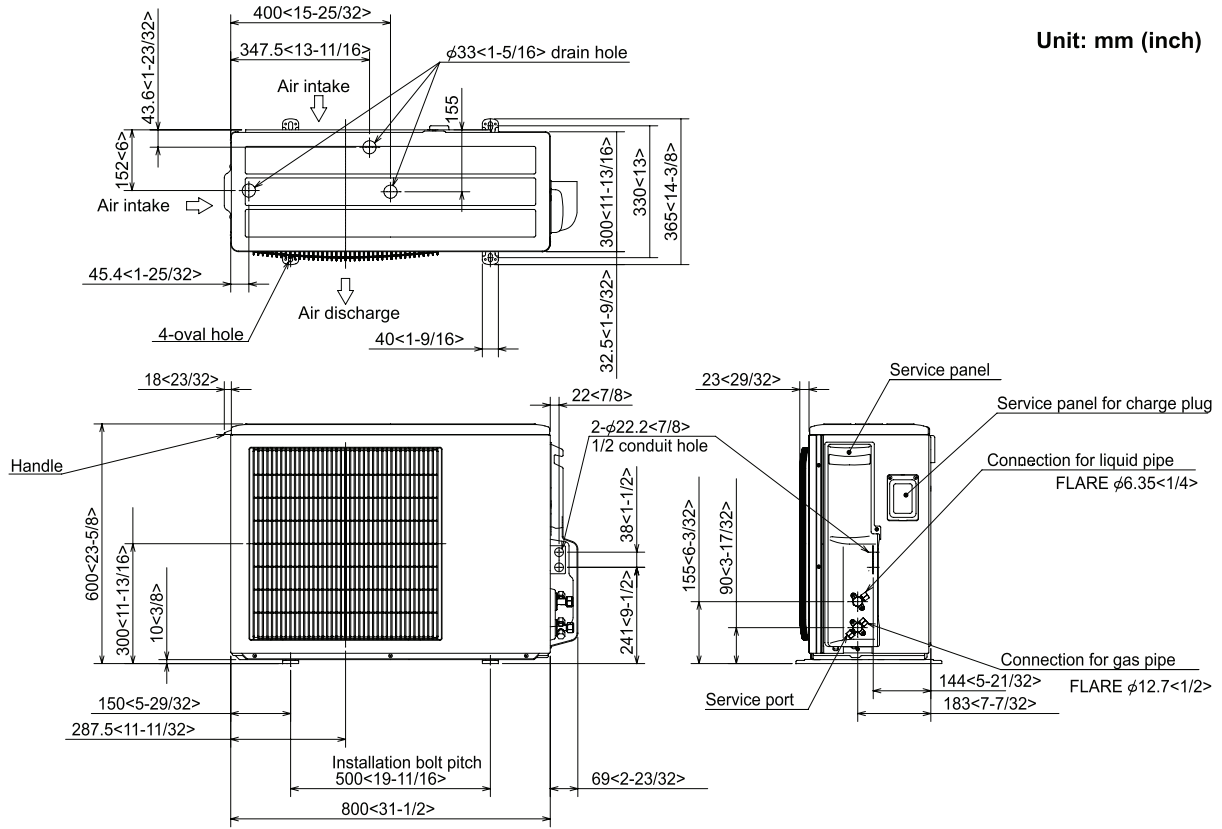

### Clearance space around the outdoor unit

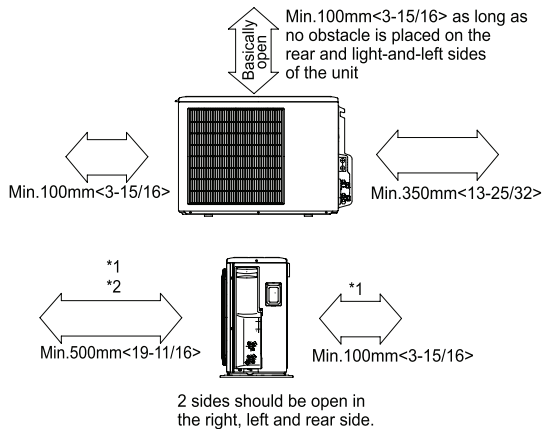

### FOUNDATION BOLTS

Please secure the unit firmly with 4 foundation M10<W3/8> bolts. (Bolts, washers and nut must be purchased locally.)

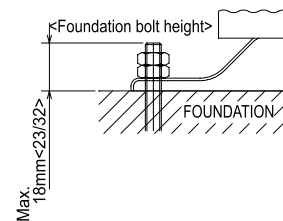

### PIPING-WIRING DIRECTION

Piping and wiring connection can be made from the rear direction only.

### Minimum installation space for outdoor unit

- \*1 In the place where short cycle tends to occur, cooling and heating capacity and power consumption might get lowered 10%. Air outlet guide (optional) will help them improve.
- \*2 If air discharges to the wall, the surface might get stained.



**HVAC Advanced Products Division**  
 3400 Lawrenceville Suwanee Rd  
 Suwanee, GA 30024  
 Tele: 678-376-2900 • Fax: 800-889-9904  
 Toll Free: 800-433-4822 (#3)  
 www.mehvac.com  
**Specifications are subject to change without notice.**